

Camand[®] Multax

for Microsoft[®] Windows NT[™] and UNIX[®]

*Provides
simultaneous
5-axis CNC toolpath,
plus full surface
modeling and
visualization.*

Camand Multax

Camand[®] Multax software combines all the modeling and NC features found in Camand Machinist along with full 5-axis machining capabilities. You get the benefits of superb surface modeling, superior 3-axis multiple surface machining, and unequaled simultaneous 5-axis machining – all in a single package.

Surface Modeling

Camand Multax offers a set of freeform and constructive NURBS surface types so you can interactively create an accurate representation of the part's shape. Surface types supported by Camand Multax include revolved, tabulated, and ruled constructive surfaces, as well as swept, patch, lofted, mesh of curves, blend, constant, and variable radius fillet surfaces.

Surface editing functions include automatic surface trimming and untrimming, blending between surfaces, forcing tangency between surfaces, splitting surfaces along iso-parametric curves, automatic generation of parting lines, and local deformation of surfaces. Surface smoothing and data reduction are also available.

3-Axis Multi-Surface Machining

Multi-surface machining is done with several types of machining methods: 1) Roughing, which removes the material between the defined stock and the surface model; 2) Parallel Plane Machining[™], which moves the cutter in a parallel, straight-line motion; 3) Swept Plane Machining, which moves the cutter in a straight-line motion that is not parallel; 4) Projection Machining, which defines the cutter motion by projecting user-defined curves or surface parametric curves onto the surface model; 5) Contour Finishing, which keeps the cutter in constant Z planes as it machines the contour of the surface model; and 6) Dual Contact Machining, which keeps the tool tangent to two sets of surfaces.

These remarkably fast machining options generate toolpaths over any number of trimmed or untrimmed surfaces, with concurrent gouge detection, correction, and collision avoidance. The software checks interference against the cutter, shank, and holder. Multiple entry, exit, and transition options provide full control over the cutter.

5-Axis Surface Machining

The system offers graphic NC programming for 5-axis machining with various machining styles.

Axis Normal

Axis Normal is a common 5-axis machining mode that positions the cutter normal (3-D

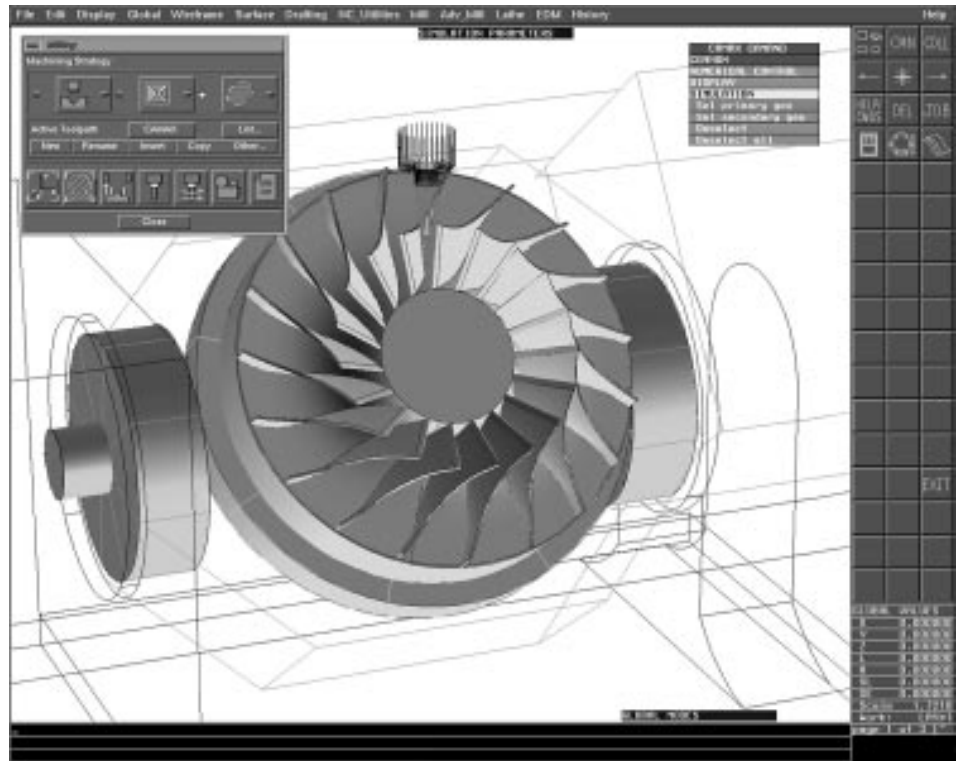

Camand Multax.

perpendicular) to the part surface being machined. Camand Multax offers a special “shift” option that moves the cutter contact point away from the cutter center to increase machining efficiency and reduce tool wear.

Through Point

Through Point helps machine parts with deep pockets, steep sidewalls, or undercuts. You simply specify a point in space (above or below the work) that the axis of the cutter must pass through.

Tilt (Lead/Lag)

Tilt (Lead/Lag) generates toolpaths with a tilted cutter axis for optimal machining efficiency, letting you control cutter positioning. The software automatically detects and corrects for heel gouging by increasing the lead angle.

Swarf

Swarf machining uses the side of the cutter for machining. The cutter is oriented tangent to the surface at the lowest point on the cutter side. The cutter axis points in the surface flow direction, roughly 90 degrees in the direction of travel.

Radial Axis

Radial Axis lets you position the cutter by projecting the cutter axis to a line that you define. This feature constrains the movement of the axis and is widely used for radial machining.

Fixed Axis

Fixed Axis is used to cut in three axes on 5-axis machines. The cutter axis you define remains fixed until a change is specified. This also controls the direction from which the cutter will approach the work.

Axis-To-Plane

Axis-to-Plane is used in 4-axis machining operations. You define a plane that is used for machining orientation; all cuts are made in a position parallel to the defined plane, constraining one of the axes of motion.

Axis Interpolation

Axis Interpolation predefines cutter axis orientations at specified positions on the geometry to be machined. The cutter axis transitions smoothly between the predefined axes. You can define four axes for each surface and two axes for each curve.

Precise Toolpaths

When you combine Camand Multax’s automatic gouge checking, collision avoidance, graphic toolpath generation display, and machining simulation, you know your NC programs are accurate before they go to the shop floor.

Machining Simulation

In addition to many other visualization features within the system, Camand Multax’s machining simulation provides the ability to visualize the motion of the part, machine tool, and cutter as additional prove-out before sending the program to the shop floor. Using the same algorithms as the post processor, toolpaths are then processed so you can view the machine, part, and cutter in simultaneous motion.

Productive Coexistence

Since Camand Multax exchanges data with virtually any other CAD system, you can expand your modeling and manufacturing options by integrating Camand Multax into your operations. Through IGES, VDA, DXF and other direct translations, Camand can leverage the investment made in geometric models created on other systems. Your existing CAD/CAM/CAE environment remains intact to protect your investment in software, hardware, and internal operations.

Call Today

For more information on how Camand Multax can contribute to your productivity and profits, call your local CAMAX dealer. For dealer information, contact CAMAX at (800) 394-5300 or (612) 854-5300.

CAMAX
SDRC’s CAM Business

7851 Metro Parkway
Minneapolis, MN 55425-1528
Phone: (612) 854-5300
Fax: (612) 854-6644
Web address: www.camax.com

Camand is a registered trademark and Parallel Plane Machining is a trademark of CAMAX Manufacturing Technologies, Inc., a wholly-owned subsidiary of Structural Dynamics Research Corporation. All other trademarks or registered trademarks belong to their respective holders.

©1996 CAMAX Manufacturing Technologies, Inc. All rights reserved.